

MecALAC

MDX
SERIES



MDX
SERIES **MecALAC**



3.5MDX

6MDX

9MDX



MDX SERIES

THE COMBINATION OF SAFETY AND DESIGN

For Mecalac, there is no such thing as small machines or small challenges. In the development of its dumpers, the safety of users was non-negotiable – whatever the cost. With its knowhow in applying practical innovation, the R&D department has transformed the 3.5-, 6- and 9-tonne dumpers by incorporating added value. By taking a fresh look at a machine and imagining an operator environment that “changes everything” has resulted in no equivalent on the market whilst maintaining the existing design of Mecalac dumpers.

3.5.MDX

COMFORT SAFETY

- Large curved windscreen
- Excellent all around visibility
- Optional screen guard

- Swivel tip skip or Front tip skip
- Large capacities up to 3.5-tonne payload
- Best efficiency to material movement

Equipment for use on the road:

- Reverse mirrors
- Road lights
- Reverse alarm
- Homologation kits

- Cab mounted on isolating mounts
- Vibration and noise reduction



- Fully enclosed ROPS/FOPS cabin
- Designed and tested to withstand impact
- Safety & Comfort in all conditions



- Hydrostatic transmission
- Easy, safe and comfortable drive

- High visibility steps and handrails
- Easy and safe access



SHIELD adjustable safety technologies as standard:

Safety start interlock system, Parking brake reminder, Machine start signal, Seat belt reminder, Engine hood open warning, Automatic engine idle shutdown, Auto Start/Stop driver presence, Mass fuel loss warning, Service required warning, Regulatory speed limiter, Parking brake test

COMPACTNESS ETTY



WATCH THE VIDEO

- Heating and ventilation as standard
- Air conditioning as an option
- Best thermal comfort

- Green Beacon seatbelt indicator and LED amber beacon

- Turbocharged 37kW (50hp) engine
- Stage V compliant
- Powerful and reliable

- Simple and well positioned controls
- Easy and pleasant drive

- Large engine doors on both sides
- Easy and safe servicing from ground level

- Cast iron rear protection
- Integrated LED lights
- Components protection

- Articulated and oscillating chassis
- Maneuverability and off-road capability



MyMecalac telematics (option)

Optimized and accessible machine data

- Large curved windscreen
- Excellent all around visibility
- Optional screen guard

- Swivel tip skip or Front tip skip
- 6-tonne (6MDX) or 9-tonne (9MDX) payload
- Large carrying capacities for best efficiency

- Cab mounted on isolating mounts
- Vibration and noise reduction



- Heating and ventilation as standard
- Air conditioning as an option
- Best thermal comfort

- Fully enclosed ROPS/FOPS cabin
- Designed and tested to withstand impact
- Safety & Comfort in all conditions



- Hydrostatic transmission now available
- Easy, safe and comfortable drive

- Cast iron rear protection
- Integrated LED lights
- Components protection



SHIELD adjustable safety technologies as standard:

Safety start interlock system, Parking brake reminder, Machine start signal, Seat belt reminder, Engine hood open warning, Automatic engine idle shutdown, Auto Start/Stop driver presence, Mass fuel loss warning, Service required warning, Regulatory speed limiter, Parking brake test

LY COMFORT VISIBILITY



WATCH THE VIDEO

-
- ROPS foldable roll bar now available
 - Ease of transportation
 - Green Beacon seatbelt indicator and LED amber beacon
 - Equipment for use on the road
 - Reverse mirrors
 - Road lights
 - Reverse alarm
 - Homologation kits
 - Simple and well positioned controls
 - Easy and pleasant drive
 - Front-view camera (standard)
 - Rear-view camera (option)
 - Integrated dashboard screen
 - Turbocharged 55 kW (74hp) engine
 - Stage V compliant
 - Powerful and reliable
 - Articulated and oscillating chassis
 - Maneuverability and off-road capability
 - High visibility steps and handrails
 - Easy and safe access



MyMecalac telematics (option)
Optimized and accessible machine data



MDX

DESIGN - LOGISTICS OF THE JOBSITE

AN EFFICIENT SOLUTION TO MATERIAL MOVEMENT ON YOUR JOB SITE

Site dumpers are a simple concept that can quickly change the dynamic of a jobsite. Compact and manoeuvrable machines capable of carrying payloads of up to 9 tons, they provide an efficient solution to material movement on the jobsite.

The dumpers ability to work in confined spaces and in a wide range of ground conditions sets them apart from road going trucks typically used for material movement. The large carrying capacity significantly reduces the number of cycles required to move material when compared to either a wheeled loader or skid steer, increasing efficiency, reducing site traffic and ground disturbance.

These attributes create a machine that is a cost effective and efficient off highway material movement solution.







MDX

SAFETY CONSCIOUS

Alongside the cab conforming to ROPS/FOPS, safety has been prioritised by incorporating MDX design characteristics which results in easier and safer access to the machine, outstanding all around visibility and a higher level of operator protection in any situation.

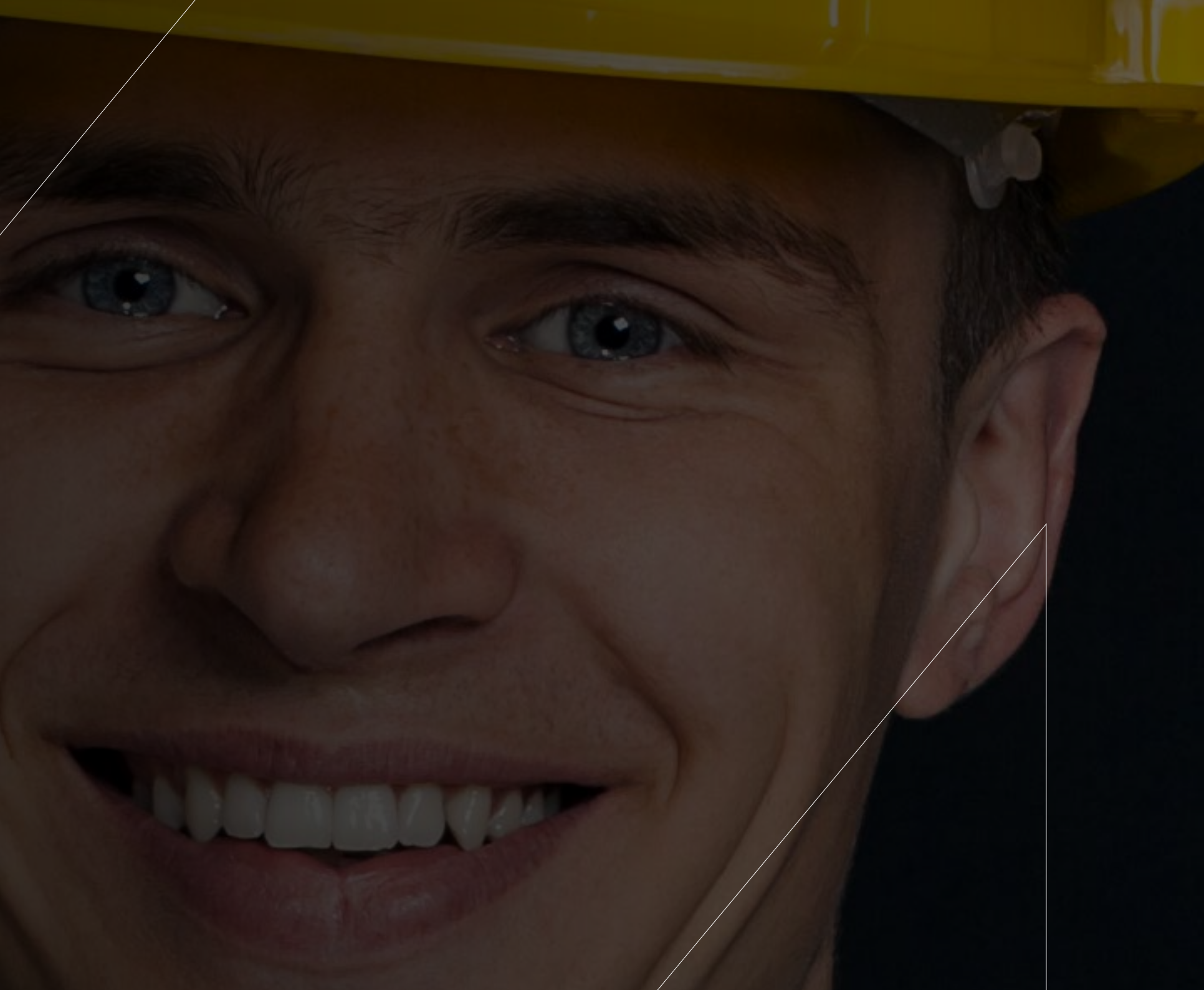

WATCH THE VIDEO





SAFETY CONSCIOUS

EXCELLENT ACCESS

**ENTERING AND EXITING THE MACHINE
IS ALWAYS SAFE DUE TO THE STAIR-LIKE
ACCESS**

*Thanks to the large stair like steps and full length
grab rails the operator is able access the cabin
without excess effort or taking any risks.*

The completely redesigned access system for the MDX site dumpers features large self clearing foot steps organised like a stairway, the solid back plate significantly reduces the risk of material build up on the steps, increasing safety. With a full length hand rail located on the A-pillar and a door mounted hand rail, 3 points of contact can be easily maintained when accessing the cabin.







SAFETY CONSCIOUS

OPERATORS ENVIRONMENT

WHETHER THE FULLY GLAZED CABIN OR ROPS BAR, OPERATOR COMFORT AND ERGONOMICS ARE ALWAYS CONSIDERED

Thanks to the cabin mounted on isolating mounts, the unique design of the Mecalac MDX range of dumpers reduces the vibration and noise transmitted to the operator. Well positioned operator controls ensure a comfortable working environment for the operator.







SAFETY CONSCIOUS

VISIBILITY ISO5006 COMPLIANT

**EXCELLENT ALL AROUND NATURAL
VISIBILITY AND A FORWARD FACING
CAMERA ENSURE A SAFE MACHINE ON
SITE THAT IS FULLY COMPLIANT**

Whether with the ROPS bar or with the cabin featuring wide A-pillar positioning and curved front windscreen, the fully integrated dash board guarantees there are no extra screens or brackets that could hamper visibility. The addition of the forward facing camera ensures compliance to ISO5006.





SAFETY CONSCIOUS



SHIELD SAFETY TECHNOLOGIES

MECALAC'S SAFETY PACK AS STANDARD

To ensure the safest site dumper on the market, Mecalac has developed a whole range of SHIELD safety technologies that aim to achieve optimum levels of safety on the MDX range of site dumpers. As standard all MDX site dumpers are fitted with the SHIELD technology pack. Further safety is offered by upgrading to the SHIELD PRO pack.



PROTECT THE OPERATORS

SHIELD technology offers unique solutions to protect the operators during the working day:



SAFETY START INTERLOCK SYSTEM:

Safety sequence – Sit, Belt, Start – before driving the machine to ensure the correct use of the seat belt



PARKING BRAKE REMINDER: The engine only starts if forward/reverse lever is in neutral position and if the parking brake is engaged



SEAT BELT REMINDER: Warning if seatbelt is not fastened while machine is moving

On demand:



MACHINE START SIGNAL: Warns the surrounding persons that the machine is starting



REGULATORY SPEED LIMITER: Maximum speed set at the factory for regulation purposes (such as TUV) with no ability to adjust



PROTECT YOUR MACHINE

SHIELD technology also monitors your machine to ensure that everything is working safely and smoothly:



ENGINE HOOD OPEN WARNING: Indicates that the engine hood is not properly closed



SERVICE REQUIRED WARNING: Provides an alert to the operator that a service is due soon



MASS FUEL LOSS WARNING: Reports a fuel theft or a major leak to the driver



PARKING BRAKE TEST: Alerts the operator that a handbrake test is required



PROTECT YOUR SAVINGS

START/STOP and Idle shut off ensure the machine is not left running for longer than required, saving fuel and reducing operating hours, therefore extending service intervals and maintaining residual value:



AUTOMATIC ENGINE IDLE SHUTDOWN: Shuts off the engine if idle time reaches 15 minutes



AUTO START/STOP DRIVER PRESENCE: Automatically stop the machine when the operator leaves the seat and restart when they return





SAFETY CONSCIOUS



SHIELD PRO FOR ULTIMATE PROTECTION

ADDITIONAL BENEFITS AND FEATURE CUSTOMIZATION

SHIELD PRO optional pack offers additional benefits such as the safe working angle monitoring and the adjustable speed limiter to further enhance the safety of the machine. Moreover, all SHIELD safety features become adjustable with the SHIELD PRO pack to suit different applications and can be disabled where not required. Following elements are included with the SHIELD PRO pack:

- Bluetooth adapter that allows wireless connection to the machine
- Dedicated free app to access all SHIELD settings using a smartphone or tablet
- Possibility to adjust speed limits, timers, and angles (i.e.: maximum speed of the machine, timer of the engine idle shutdown system...)
- Possibility to activate/deactivate some features



**SHIELD SAFETY
FUNCTIONS CAN BE
ADJUSTED TO SUIT
DIFFERENT APPLICATIONS
WHERE THESE ARE NOT
REQUIRED.**



CUSTOM SPEED LIMITER Safe Site Management

Using the downloadable application it is possible to adjust via bluetooth the maximum speed that the machine can travel.



SAFE WORKING ANGLE MONITORING

- **MACHINE TILT MONITORING:** The machine is constantly monitoring the angle at which it is operating, a warning is given when approaching the maximum safe working angle. If needed and when the maximum angle is reached, the engine rpm could be limited to stop the machine progressing into a further unstable situation.



ENSURE SAFETY DURING UNLOADING OPERATIONS

- **SKIP INTERLOCK:** When the machine speed is above 5km/h the operation of the skip is removed
- **TIPPED SKIP SPEED LIMITER:** If the skip is raised, the machine travel speed will be limited to 5km/h



PREVENT ACCIDENTS ON SITE

- **HAZARD DETECTION SYSTEM READY:** Harness and connectors fitted ready to accept the hazard detection radar unit
- **ROLL- OVER LOCKOUT:** In the event of roll-over of the machine, the engine is shut-down and locked out. A service engineer is then required to reset the machine and ensure a safe restart



MDX

OPTIMAL PERFORMANCE

MDX machines are equipped with numerous technical characteristics for optimal efficiency on all types of terrain.



WATCH THE VIDEO

Mecalac

EM DX

Mecalac

EM DX



PERFORMANCE

OFF-ROAD MOBILITY

AN ARTICULATED AND OSCILLATING CHASSIS ENSURES THE MDX RANGE OF DUMPERS HAVE EXCELLENT MANOEUVRABILITY AND OFF-ROAD CAPABILITY

All Mecalac site dumpers are designed with high ground clearance to enable operation on the roughest terrain. Permanent 4 wheel drive and large oscillation angles ensure the wheels keep in contact with the ground and maintain traction in all conditions.

Large turning angles ensure the machines remain manoeuvrable so that access to difficult locations remains possible with the 9MDX being the most manoeuvrable dumper in its class!





PERFORMANCE

HYDROSTATIC TRANSMISSION

SINGLE PEDAL, TOTAL CONTROL

The hydrostatic drive system ensures easier operations without changing gears and delivers smooth, uninterrupted power for the operator and high travel speed.

When working on gradients, the hydrostatic braking technology offers responsive dynamic braking, resulting in a pleasant driving feeling. This also makes operation safer for both experienced and new operators, meaning the MDX site dumpers are perfect for rental fleets and frequent changing operators.



Mecalac

Mecalac



PERFORMANCE

ROBUSTNESS BUILT IN!

**ALMOST 70 YEARS OF DUMPER
PRODUCTION HAS LEAD
TO MACHINES DESIGNED
SPECIFICALLY TO MEET THE
TOUGH DEMANDS OF NEW
CONSTRUCTION SITES**

“Rental tough” site dumper design has ensured that Mecalac site dumpers have remained a long lasting and reliable part of your business. The use of solid rear panels ensures the highest level of protection to the cooling pack and engine, the latest design also see the addition of LED lights that are recessed into the casting for excellent protection.





PERFORMANCE

VERSATILITY

**WHETHER CARRYING OUT
BULK MATERIAL MOVEMENT
OR WORKING IN CONFINED
SPACES WE HAVE A SKIP
DESIGN SUITABLE**

Choose between the front tip skip and the swivel tip skip to match the needs of your job site. Front tip skips offer large volumetric capacity, perfect for bulk material movement. Swivel tip skip allows the machine to deposit loads anywhere within a 180 degree arc, this allows machines to unload into trenches whilst working in a single lane of traffic.







MDX

OPERATOR INTERACTION

Ease of operator interaction has been considered with the MDX. All controls are ready to hand, large glazed areas provide great visibility and servicing has never been easier.



WATCH THE VIDEO





OPERATOR INTERACTION

USER FRIENDLINESS

EASY AND PLEASANT DRIVE

A combination of simple operator controls and an uncluttered cabin ensure the operator can carry out their tasks with ease. Operator comfort is guaranteed due to the high back operators seat and ergonomic positioning of all the machine controls.

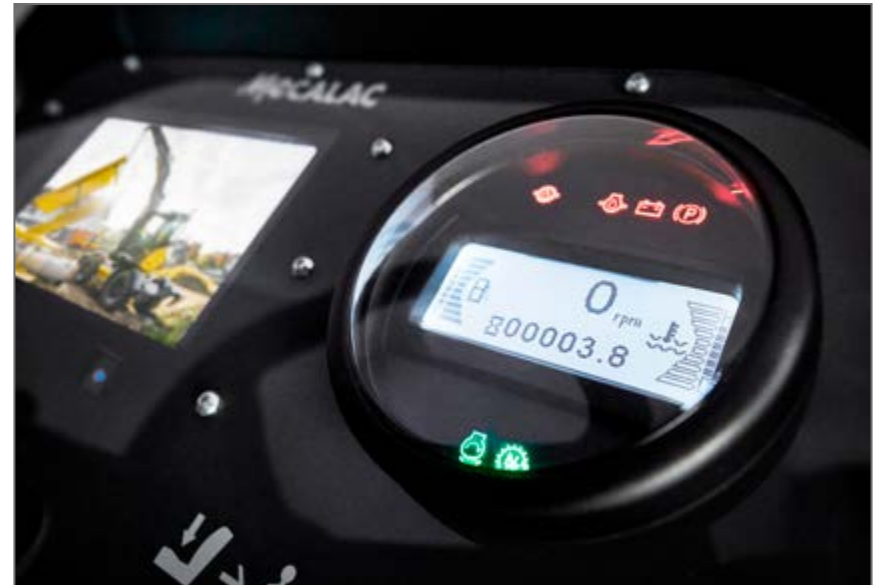



OPERATOR INTERACTION

EASE OF MAINTENANCE

EXCELLENT ENGINE ACCESS FOR SERVICING AND DAILY CHECKS

The large engine doors on both sides provide easy access into the engine bay where all daily checks can be carried out with your 'feet on the ground'. A service panel integrated into the rear of machine enables access directly into the cooling pack or ease of cleaning.



WATCH THE VIDEO

OPERATOR INTERACTION

HAZARD DETECTION

A ROBUST SOLUTION TO PROVIDE ADDITIONAL AID TO OPERATORS OF FORWARD FACING SITE DUMPERS

The system is designed to detect objects in front of the working machine which may not have been seen by the operator. A forward facing sensor combined with an audio visual alarm alert the operator when an object is within range and sequential LED lights illuminate to show which zone the object has entered. Dedicated software aims to reduce the number of unwanted warnings, such as when the machine is stationary or moving away from an object.





SERVICES

PERFORMANCE, PROFITABILITY, LONGEVITY

DISCOVER OUR SERVICES

MECALAC PREMIUM LUBRICANTS

Premium lubricants to get the best out of your machines:

- Extended machine life
- Extended warranty and extended oil change intervals
- All-weather efficiency



MY MECALAC CONNECTED SERVICES

To optimise the use of its machines, MECALAC offers a range of telematics services:

- Remote fleet management
- Access to all machine usage data of the machines
- Limited machine downtime thanks to preventive maintenance





MECALAC GENUINE PARTS

Only genuine MECALAC parts ensure optimum service life and maximum performance:

- Certified genuine parts
- Maintenance kits
- Extended warranty



MECALAC TRAINING

Make full use of the full potential of your Mecalac machines:

- Efficient use
- Individual coaching
- Intensive practice



MECALAC FINANCIAL SOLUTIONS

A complete range of financial products and associated services to meet your specific needs:

- Machine purchase
- Machine rental
- Competitive rates



WARRANTY EXTENSIONS

Our solutions are well-adapted to your needs to maximise the life of your machines:

- Customised contracts
- Peace of mind
- Controlled expenses



The list of services offered may vary depending on your country. Consult your local Mecalac dealer for details.



MDX

SET UP YOUR MDX

The new MDX comes standard equipped with a number of features, while at the same time remaining attentive to the specifications required by various types of customers: landscape and earthwork contractors, public works' professionals, municipal authorities, etc. Whether a front or swivel skip, enclosed cabin or ROPS bar, heating or AC there is a combination that will suit all requirements.

MDX

OPERATORS ENVIRONMENT



SKIP TYPE



TRANSMISSION



STANDARD FEATURES



AVAILABLE OPTIONS





MDX

TECHNICAL DATA

3.5 MDX

Mec

MECALAC

3.5.MDX

TECHNICAL DATA

	3.5MDX - FRONT TIP SKIP Hydrostatic - CAB	3.5MDX - SWIVEL TIP SKIP Hydrostatic - CAB
SKIP CAPACITY		
Payload	3500 kg (7716 lbs)	3500 kg (7716 lbs)
Skip type	Front tip skip	Swivel tip skip
Skip volume - Water	1250 l	1000 l
Skip volume - Struck	1685 l	1520 l
Skip volume - Heaped	2206 l	1880 l
MACHINE WEIGHT		
Operating weight ISO6016 – full tank of fuel and 75kg (165 lbs) operator - Cab	2840 kg (6261 lbs)*	2990 kg (6592 lbs)
ENGINE		
Manufacturer/Model	Kubota D1803-CR-TE5B	
Emission regulation	EU Stage V / U.S. EPA Tier 4 Final*	
Type	Water-cooled 3-cylinder diesel	
Displacement	1826 cm ³ (111.4 in ³)	
Gross power (DIN 70020)	37.0 kW (50hp)	
Maximum torque	150.5 Nm (110 ft.lbf) at 1600 rpm	
Maximum engine speed	2900 rpm	
Aspiration	Turbocharged	
Fuel system	Common Rail system	
Aftertreatment	Diesel Oxidation Catalyst (DOC) + Diesel Particulate Filter (DPF)	
TRANSMISSION		
Type	Hydrostatic Hydrostatic Motor via Transfer Box to Front & Rear Axles	
Traction	Permanent 4 wheel-drive	
Drive	2/2: high and low range - forward and reverse	
Flow rate	112 l/min (29.6 US gpm)	
Working pressure	450 bar (6527 psi)	
DRIVE CHARACTERISTICS		
Maximum turning radius	4685 mm (15'4")	4555 mm (14'11")
Maximum speed	20 kph (12.4 mph)	
Chassis	Articulated and oscillating	
Steering angle	+/-30°	
Oscillation angle	+/-10.5°	
Gradeability (defined by maximum safe working angle)	25%	
Tyre Size	295-80-15.3 (10 PR)	
HYDRAULIC SYSTEM		
Pump type	Gear pump	
Flow rate	29 l/min (7.66 US gpm)	
Operating pressure	210 bar (3045.7 psi)	
Steering system	Orbitrol hydrostatic steering unit powering a central hydraulic steering cylinder	
BRAKING SYSTEM		
Working brake	Multi-plate inboard oil immersed disc on front axle	
Parking brake	Spring applied hydraulic release (SAHR) - Oil immersed discs on front axle	
EMISSIONS		
Noise emission (ISO 4871) – Operators ear sound pressure (LpAd)	82 dB	
Noise emission (ISO 4871) – Machine Noise Power (LWAd)	102 dB	
Noise compliance	Noise - Equipment used outdoors directive 2000/14/EC	
Hand arm vibration (defined by EN474-1 for all operations)	<2.5 m/s ²	
Whole body vibration (defined by ISO/TR25398 for a work cycle)	0.529 (0.264 m/s ² uncertainty)	
TANK CAPACITIES		
Fuel tank	37 l (9.77 US gal)	
Hydraulic tank	37 l (9.77 US gal)	

*According to National regulation - Environmental Protection Agency (EPA). Specifications are subject to change.

NOTE: METRIC MEASUREMENTS ARE THE CRITICAL VALUES

• 1 Litre = 0.26417 US Liquid Gallons • 1 Litre = 0.21997 Imperial Liquid Gallons

TECHNICAL DATA

	6MDX - FRONT TIP SKIP SynchroShuttle - Cab	6MDX - SWIVEL TIP SKIP SynchroShuttle - Cab	6MDX - FRONT TIP SKIP Hydrostatic - ROPS bar / Cab	6MDX - SWIVEL TIP SKIP Hydrostatic - ROPS bar / Cab
SKIP CAPACITY				
Payload	6000 kg (13,228 lbs)	6000 kg (13,228 lbs)	6000 kg (13,228 lbs)	6000 kg (13,228 lbs)
Skip type	Front tip skip	Swivel tip skip	Front tip skip	Swivel tip skip
Skip volume - Water	1598 l	1580 l	1598 l	1580 l
Skip volume - Struck	2359 l	2399 l	2359 l	2399 l
Skip volume - Heaped	2927 l	3085 l	2927 l	3085 l
MACHINE WEIGHT				
Operating weight ISO6016 – full tank of fuel and 75kg (165 lbs) operator				
- Cab	4760 kg (10494 lbs)	4960 kg (10935 lbs)	4720 kg (10406 lbs)	4900 kg (10803 lbs)
- ROPS bar	-	-	4460 kg (9833 lbs)	4640 kg (10229 lbs)
ENGINE				
Manufacturer/Model	Perkins - 904J-E28TA			
Emission regulation	EU Stage V / U.S. EPA Tier 4 Final*			
Type	Water-cooled 4-cylinder diesel			
Displacement	2800 cm ³ (171 in ³)			
Gross power (DIN 70020)	55 kW (74hp)			
Maximum torque	380 Nm (280 ft.lbf) at 1380 rpm			
Maximum engine speed	2400 rpm			
Aspiration	Turbocharged			
Fuel system	Electronic high pressure common rail			
Aftertreatment	Diesel Oxidation Catalyst (DOC) + Diesel Particulate Filter (DPF)			
TRANSMISSION				
Type	SynchroShuttle Gearbox via transfer box to front & rear axles		Hydrostatic Hydrostatic Motor via Transfer Box to Front & Rear Axles	
Traction	Permanent 4 wheel-drive		Permanent 4 wheel-drive	
Drive	4/4 Forward and Reverse		1/1 Forward and Reverse	
Flow rate	-		234 l/min (61.8 US gpm)	
Working pressure	-		Nominal 400 bar (5802 psi) - Maximum 530 bar (7687 psi)	
DRIVE CHARACTERISTICS				
Maximum turning radius	6483 mm (21'3")	6382 mm (20'11")	6483 mm (21'3")	6382 mm (20'11")
Maximum speed	24 km/h (15 mph)		25 km/h (15.5 mph)	
Chassis	Articulated and oscillating			
Steering angle	+/-30°			
Oscillation angle	+/-10.5°			
Gradeability (defined by maximum safe working angle)	25%			
Tyre Size	405-70-20 (14 PR)			
HYDRAULIC SYSTEM				
Pump type	Gear pump			
Flow rate	74 l/min (19.5 US gpm)			
Operating pressure	210 bar (3045 psi)			
Steering system	Orbitrol hydrostatic steering unit powering a central hydraulic steering cylinder			
BRAKING SYSTEM				
Working brake	Hydraulic boosted foot Brake - Oil immersed discs on front/rear			
Parking brake	Over centre parking brake - Dry disc on gearbox output		Over centre parking brake-integrated in rear axle	
EMISSIONS				
Noise emission (ISO 4871) – Operators ear sound pressure (LpAd)	85 dB			
Noise emission (ISO 4871) – Machine noise Power (LWA _d)	101 dB			
Noise compliance	Noise - Equipment used outdoors directive 2000/14/EC			
Hand arm vibration (defined by EN474-1 for all operations)	<2.5 m/s ²			
Whole body vibration (defined by ISO/TR25398 for a work cycle)	0.529 (0.264 m/s ² uncertainty)			
TANK CAPACITIES				
Fuel tank	65 l (17.17 US gal)			
Hydraulic tank	50 l (13.2 US gal)			

*According to National regulation - Environmental Protection Agency (EPA). Specifications are subject to change.

NOTE: METRIC MEASUREMENTS ARE THE CRITICAL VALUES • 1 Litre = 0.26417 US Liquid Gallons • 1 Litre = 0.21997 Imperial Liquid Gallons

9.MDX

TECHNICAL DATA

	9MDX - FRONT TIP SKIP SynchroShuttle - Cab	9MDX - SWIVEL TIP SKIP SynchroShuttle - Cab	9MDX - FRONT TIP SKIP Hydrostatic - ROPS bar / Cab	9MDX - SWIVEL TIP SKIP Hydrostatic - ROPS bar / Cab
SKIP CAPACITY				
Payload	9000 kg (19,842 lbs)	9000 kg (19,842 lbs)	9000 kg (19,842 lbs)	9000 kg (19,842 lbs)
Skip type	Front tip skip	Swivel tip skip	Front tip skip	Swivel tip skip
Skip volume - Water	2014 l	1902 l	2014 l	1902 l
Skip volume - Struck	3775 l	3318 l	3775 l	3318 l
Skip volume - Heaped	4466 l	4096 l	4466 l	4096 l
MACHINE WEIGHT				
Operating weight ISO6016 – full tank of fuel and 75kg (165 lbs) operator				
- Cab	5375 kg (11850 lbs)	5795 kg (12776 lbs)	5315 kg (11718 lbs)	5715 kg (12600 lbs)
- ROPS bar	-	-	5055 kg (11144 lbs)	5455 kg (12026 lbs)
ENGINE				
Manufacturer/Model	Perkins - 904J-E28TA			
Emission regulation	EU Stage V / U.S. EPA Tier 4 Final*			
Type	Water-cooled 4-cylinder diesel			
Displacement	2800 cm ³ (171 in ³)			
Gross power (DIN 70020)	55 kW (74 hp)			
Maximum torque	380 Nm (280 ft.lbf) at 1380 rpm			
Maximum engine speed	2400 rpm			
Aspiration	Turbocharged			
Fuel system	Electronic high pressure common rail			
Aftertreatment	Diesel Oxidation Catalyst (DOC) + Diesel Particulate Filter (DPF)			
TRANSMISSION				
Type	SynchroShuttle		Hydrostatic	
Traction	Gearbox via transfer box to front & rear axles		Hydrostatic Motor via Transfer Box to Front & Rear Axles	
Drive	Permanent 4 wheel-drive		Permanent 4 wheel-drive	
Flow rate	4/4 Forward and Reverse		1/1 Forward and Reverse	
Working pressure	-		234 l/min (61.8 US gpm)	
	-		Nominal 400 bar (5802 psi) - Maximum 530 bar (7687 psi)	
DRIVE CHARACTERISTICS				
Maximum turning radius	6557 mm (21'6")	6464 mm (21'2")	6557 mm (21'6")	6464 mm (21'2")
Maximum speed	24 km/h (15 mph)		25 km/h (15.5 mph)	
Chassis	Articulated and oscillating			
Steering angle	+/-30°			
Oscillation angle	+/-10.5°			
Gradeability (defined by maximum safe working angle)	20%			
Tyre Size	500-60-22.5 (16 PR)			
HYDRAULIC SYSTEM				
Pump type	Gear pump			
Flow rate	74 l/min (19.5 US gpm)			
Operating pressure	210 bar (3045 psi)			
Steering system	Orbitrol hydrostatic steering unit powering a central hydraulic steering cylinder			
BRAKING SYSTEM				
Working brake	Hydraulic boosted foot Brake - Oil immersed discs on front/rear			
Parking brake	Over centre parking brake - Dry disc on gearbox output		Over centre parking brake-integrated in rear axle	
EMISSIONS				
Noise emission (ISO 4871) – Operators ear sound pressure (LpAd)	85 dB			
Noise emission (ISO 4871) – Machine Noise Power (LWAd)	101 dB			
Noise compliance	Noise - Equipment used outdoors directive 2000/14/EC			
Hand arm vibration (defined by EN474-1 for all operations)	<2.5 m/s ²			
Whole body vibration (defined by ISO/TR25398 for a work cycle)	0.529 (0.264 m/s ² uncertainty)			
TANK CAPACITIES				
Fuel tank	65 l (17.17 US gal)			
Hydraulic tank	50 l (13.2 US gal)			

*According to National regulation - Environmental Protection Agency (EPA). Specifications are subject to change.

NOTE: METRIC MEASUREMENTS ARE THE CRITICAL VALUES • 1 Litre = 0.26417 US Liquid Gallons • 1 Litre = 0.21997 Imperial Liquid Gallons

3.5.6.9.MDX DIMENSIONS

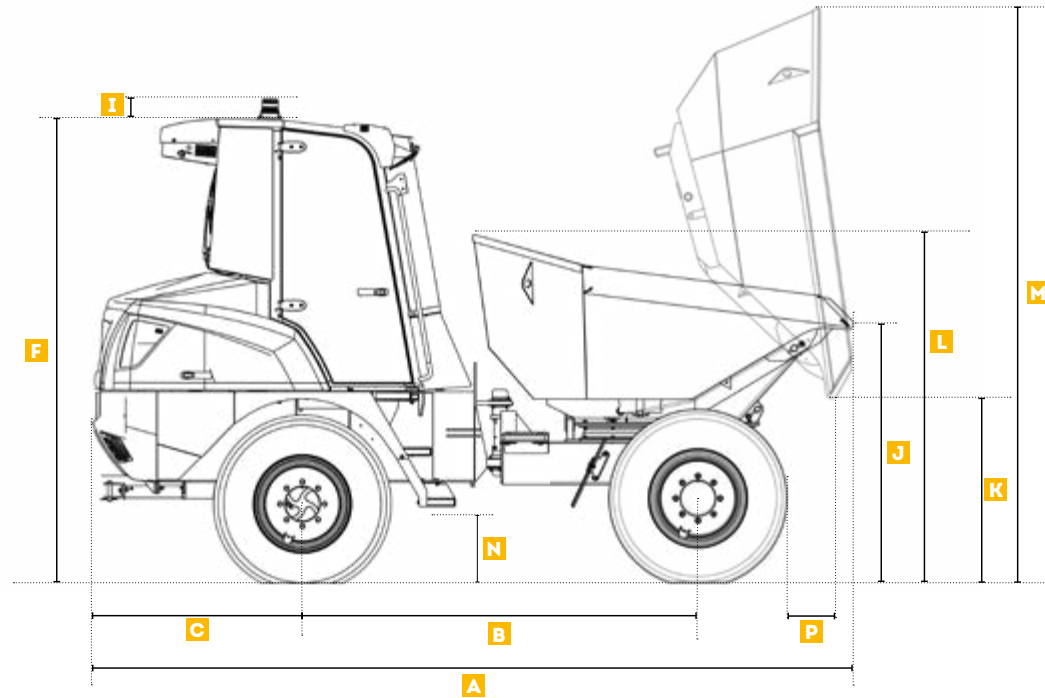

Illustration not contractual

MACHINE DIMENSIONS	3.5MDX		6MDX		9MDX	
	FRONT TIP mm (ft in)	SWIVEL TIP mm (ft in)	FRONT TIP mm (ft in)	SWIVEL TIP mm (ft in)	FRONT TIP mm (ft in)	SWIVEL TIP mm (ft in)
A Overall length	3821 (12'6")	4012 (13'2")	4454 (14'7")	4711 (15'5")	4587 (15'1")	4735 (15'6")
B Wheelbase	1939 (6'4")	1939 (6'4")	2450 (8')	2450 (8')	2450 (8')	2450 (8')
C Rear overhang	1124 (3'8")	1124 (3'8")	1287 (4'3")	1287 (4'3")	1293 (4'3")	1293 (4'3")
D Total width	1957 (6'5")	1846 (6'1")	2300 (7'7")	2211 (7'3")	2389 (7'10")	2364 (7'9")
E Skip width	1957 (6'5")	1685 (5'6")	2300 (7'7")	2211 (7'3")	2389 (7'10")	2341 (7'8")
F Overall height of cab	2663 (8'9")	2663 (8'9")	2875 (9'5")	2875 (9'5")	3384 (11'1")	3384 (11'1")
G Overall height of ROPS - unfolded	-	-	2906 (9'6")	2906 (9'6")	3389 (11'1")	3389 (11'1")
H Overall height of ROPS - folded	-	-	2285 (7'6")	2285 (7'6")	2798 (9'2")	2798 (9'2")
I Additional height for beacon	130 (5")	130 (5")	130 (5")	130 (5")	130 (5")	130 (5")
J Height to lip of skip - untipped	1419 (4'8")	1469 (4'10")	1581 (5'2")	1685 (5'6")	1682 (5'6")	1827 (5'12")

3.5.6.9.MDX

DIMENSIONS

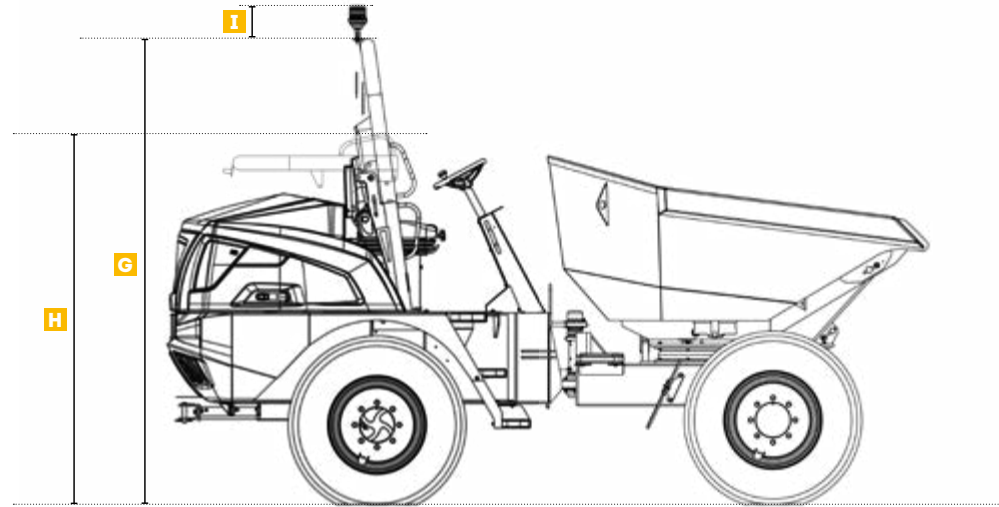
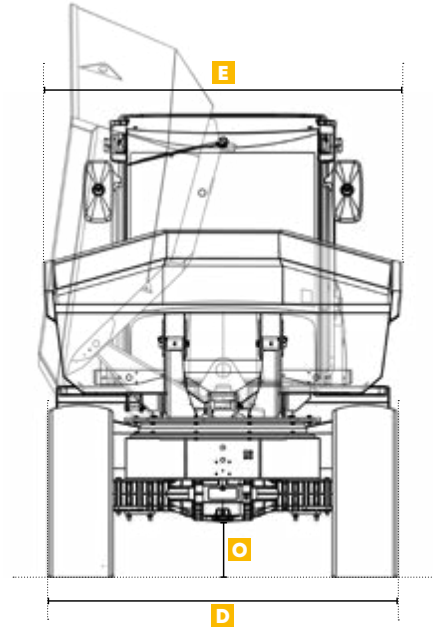

Illustration not contractual

MACHINE DIMENSIONS	3.5MDX		6MDX		9MDX	
	FRONT TIP mm (ft in)	SWIVEL TIP mm (ft in)	FRONT TIP mm (ft in)	SWIVEL TIP mm (ft in)	FRONT TIP mm (ft in)	SWIVEL TIP mm (ft in)
K Height to lip of skip - tipped	248 (10")	841 (2'9")	430 (1'5")	1126 (3'8")	462 (1'6")	1171 (3'10")
L Height of skip - untipped	1820 (5'12")	1805 (5'11")	1998 (6'7")	2167 (7'1")	2292 (7'6")	2483 (8'2")
M Height of skip - tipped	1973 (6'6")	2904 (9'6")	2379 (7'10")	3545 (11'8")	2746 (9')	3782 (12'5")
N Height to first step	518 (1'8")	518 (1'8")	472 (1'7")	472 (1'7")	509 (1'8")	509 (1'8")
O Minimum ground clearance	217 (8")	217 (8")	347 (1'2")	347 (1'2")	396 (1'4")	396 (1'4")
P Discharge distance - front	550 (1'10")	526 (1'9")	513 (1'8")	354 (1'2")	583 (1'11")	408 (1'4")
Discharge distance - side	-	209 (8")	-	16 (0'6")	-	12 (0.5")

STANDARD / OPTIONAL EQUIPEMENT

	3.5MDX	6MDX		9MDX	
	Front / Swivel tip skip Hydrostatic transmission	Front / Swivel tip skip SynchroShuttle transmission	Front / Swivel tip skip Hydrostatic transmission	Front / Swivel tip skip SynchroShuttle transmission	Front / Swivel tip skip Hydrostatic transmission
OPERATOR ENVIRONMENT					
ROPS foldable roll bar			•		•
Cab ROPS/FOPS fully enclosed and comfortable	•	•	o	•	o
Cab heating and ventilation system	•	•	• (Cab only)	•	• (Cab only)
Cab Air-conditioning system	o	o	o (Cab only)	o	o (Cab only)
Wide leg guard protection			o (Rops only)		o (Rops only)
Multifunctional display screen integrated into the dashboard	•	•	•	•	•
Adjustable ergonomic seat	•	•	•	•	•
High visibility orange seatbelt	•	•	•	•	•
SAFETY					
High visibility safety decals steps and handrails	•	•	•	•	•
Front-view camera with screen integrated into the dashboard		•	•	•	•
Rear-view camera with screen integrated into the dashboard		o	o	o	o
Rear-view mirrors	•	•	• (Cab only) o (Rops only)	•	• (Cab only) o (Rops only)
Cab front screen guard	o	o	o (Cab only)	o	o (Cab only)
Reverse Alarm	•	•	•	•	•
Fan Guard	•	•	•	•	•
Hazard / Object detection system	o	o	o	o	o
Hazard / Object detection system (system ready)	o	o	o	o	o
CESAR Datatag security kit (UK only)	o	o	o	o	o
SHIELD SAFETY TECHNOLOGIES					
SHIELD Safety Technology Pack Safety start interlock system, Parking brake reminder, Machine start signal, Seat belt reminder, Engine hood open warning, Automatic engine idle shutdown, Auto Start/Stop driver presence, Mass fuel loss warning, Service required warning, Regulatory speed limiter, Parking brake test					
	•	•	•	•	•
SHIELD PRO Safety Technology Pack Machine tilt monitoring, Tipped skip speed limiter and skip interlock, Roll-over lockout, Hazard detection system ready, Customization of shield features on the machine (Bluetooth adapter and dedicated free app), Possibility to switch on/off features, Possibility to adjust speed limits, timers, and angles					
	o	o	o	o	o

Country packs available

- = Standard
- o = Optional

Standard and optional equipment may vary. Consult your Mecalac dealer for details.

STANDARD / OPTIONAL EQUIPEMENT

	3.5MDX		6MDX		9MDX	
	Front / Swivel tip skip Hydrostatic transmission	Front / Swivel tip skip SynchroShuttle transmission	Front / Swivel tip skip SynchroShuttle transmission	Front / Swivel tip skip Hydrostatic transmission	Front / Swivel tip skip SynchroShuttle transmission	Front / Swivel tip skip Hydrostatic transmission
LIGHTING						
LED Amber flashing beacon	•	•	•	•	•	•
Green Beacon seatbelt indicator	•	•	•	•	•	•
LED Front and rear work lights	•	•	• (Cab only)	•	•	• (Cab only)
Certified Road Lights Front and Rear - including Light Guards	o	o	o	o	o	o
Road Lights ready (Inc. Wiring and brake sensor)	o	o	o	o	o	o
COLOUR & BRANDING						
Standard machine colour - Mecalac Yellow & Grey	•	•	•	•	•	•
Custom machine colour	o	o	o	o	o	o
Mecalac Standard Branding	•	•	•	•	•	•
Mecalac Rental Branding - clear skip sides	•	•	•	•	•	•
TELEMATICS						
MyMecalac Telematics - including app	o	o	o	o	o	o
OTHERS						
Articulated and oscillating chassis	•	•	•	•	•	•
Traction tyres	•	•	•	•	•	•
Towing/Recovery Bracket	•	•	•	•	•	•
Heavy-duty articulation lock	•	•	•	•	•	•
Loose Wheel Nut Indicator	o	o	o	o	o	o
Spare Wheel	o	o	o	o	o	o
Biodegradable Hydraulic Oil	o	o	o	o	o	o
German / Swiss Road Homologation kit	o	o	o	o	o	o
UK Vehicle Registration & Road Fund Licence 12 Months (UK only)	•	•	•	•	•	•

Country packs available

• = Standard
o = Optional

Standard and optional equipment may vary. Consult your Mecalac dealer for details.

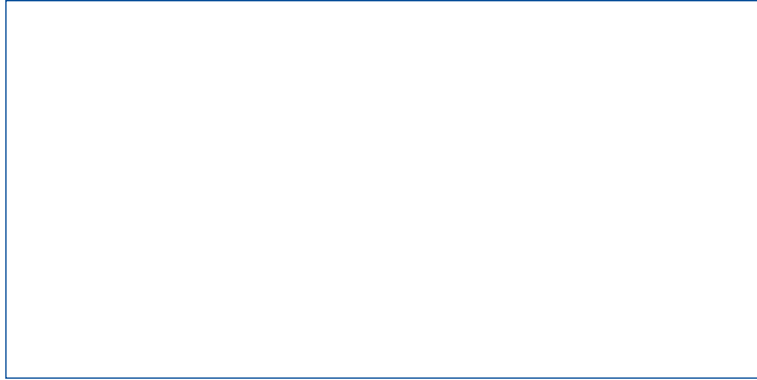

MECALAC FRANCE S.A.S.
2, avenue du Pré de Challes
Parc des Glaisins – CS 40230
Annecy-le-Vieux
FR - 74942 Annecy Cedex
Tel. +33 (0)4 50 64 01 63

**MECALAC BAUMASCHINEN
GMBH**
Am Friedrichsbrunnen
D-24782 Büdelsdorf
Tel. +49 (0)43 31/3 51-319

**MECALAC CONSTRUCTION
EQUIPMENT UK LTD**
Unit 1, Mallory Way
Gallagher Business Park
Coventry, CV6 6PB, UK
Tel. +44 (0)24 7633 9400

**MECALAC İŞ MAKİNELERİ
SAN. VE TİC. LTD. ŞTİ.**
Ege Serbest Bölgesi
Zafer SB Mahallesi Gündüz Sokak No:17/1
35410, Gazimür - İzmir - TÜRKİYE
Tel. +90 232 220 11 15



WWW.MECALAC.COM